

BECHER AIR COMPONENTS

DIVISION OF C-ASSOCIATES, LLC

SODUS, NY 315-483-6923

OWNER'S MANUAL – BECMATIC SPRING FEEDERS

BECMATIC MODELS 550/600/602/652



MODEL	ID #	SERIAL #	FEED RATE	DATE

Spring No.	Revision

87 West Main Street
Sodus, NY 14551
(315) 483-6923 TEL
(315) 483-6656 FAX
Email:sales@becherair.com

INDEX

Warranty _____	Page 3
Return Information _____	Page 3
Setup _____	Page 4
Installation of Feed Tube(s) _____	Page 4
Mounting _____	Page 5
Operation _____	Page 10
Optional Equipment _____	Page 11
Troubleshooting _____	Page 13
Preventative Maintenance _____	Page 14
Parts List _____	Page 16
Typical Setup _____	Page 18

STANDARD WARRANTY

The seller warrants equipment of its manufacture against defects in workmanship and material for a period of 12 months from date of shipment from the factory.

This unit has been tooled specifically for your application. Air velocity and volume are preset at the factory and the case has been sealed to maintain proper airflow. Disassembly or modifications to this unit may impair operation and/or void warranty.

RETURN INFORMATION

- * Call Factory for return authorization.
- * Carefully pack unit to avoid damage in shipment. Insure for full value of the unit.
- * Include detailed description of problem, name and phone number of the contact person, a quantity of springs for test operations, and shipping instructions.

SETUP & INSTALLATION

SETUP

All models of Becmatic Spring Feeders require a 115 volt grounded electrical outlet and 80 p.s.i. of clean air. The unit may be plugged into any standard 115 volt outlet, or may be wired directly to any controller with 115 volt output. In installations where the air supply exceeds 80 p.s.i., a regulator should be provided.

The feeder should be mounted above the spring escapement to allow gravity feed of the springs through the feed tube. **Feed tube length should be kept as short as possible to eliminate excess backpressure, (36" maximum).**

INSTALLATION OF FEED TUBE(S)

The feed tube is inserted into the outlet nozzle on the front of the feeder. The lock collar should be adjusted to provide a secure grasp on the feed tube. Over tightening the lock collar will result in damage to the nozzle and may impair the travel of the springs. Feed tube length should be enough to allow a transition without kinks or sharp bends that will impede flow.

- * 230 volt models are not supplied with a plug.
- * See mounting instructions.

MOUNTING & SPECIFICATIONS

MODEL 550

	US Std. Inches	Metric (mm)
Spring O.D.	.040 - .125	1.0 – 3.2 mm
Spring Length	.625	16 mm
Capacity (Vol)	.5 qt.	.5 ltr.
Electrical	115 VAC, 1.5A	230VAC, 1A
Air	80 p.s.i.	5.6 kg/cc ²
Air Supply	.250 min.	6 mm min.

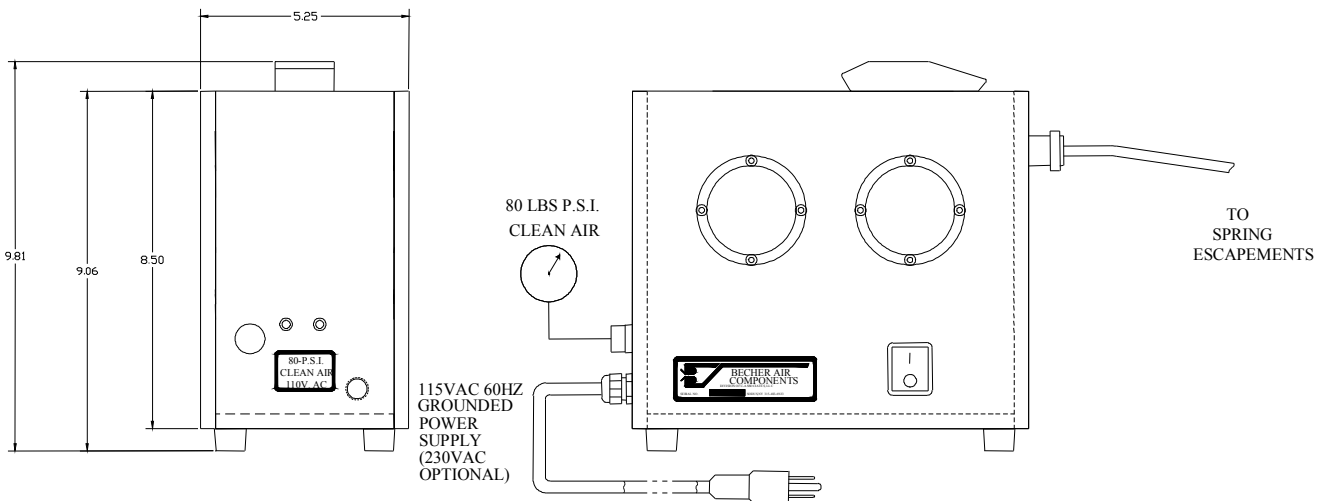
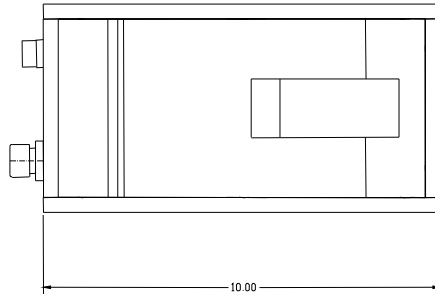

MOUNTING & SPECIFICATIONS

MODEL 600

	US Std. Inches	Metric (mm)
Spring O.D.	.125 - .312	3.2 – 8 mm
Spring Length	1.250	31.8 mm
Capacity (Vol)	1.5 qt.	1.4 ltr.
Electrical	115 VAC, 1.5A	230VAC, 1A
Air	80 p.s.i.	5.6 kg/cc ²
Air Supply	.375 min.	10 mm min.

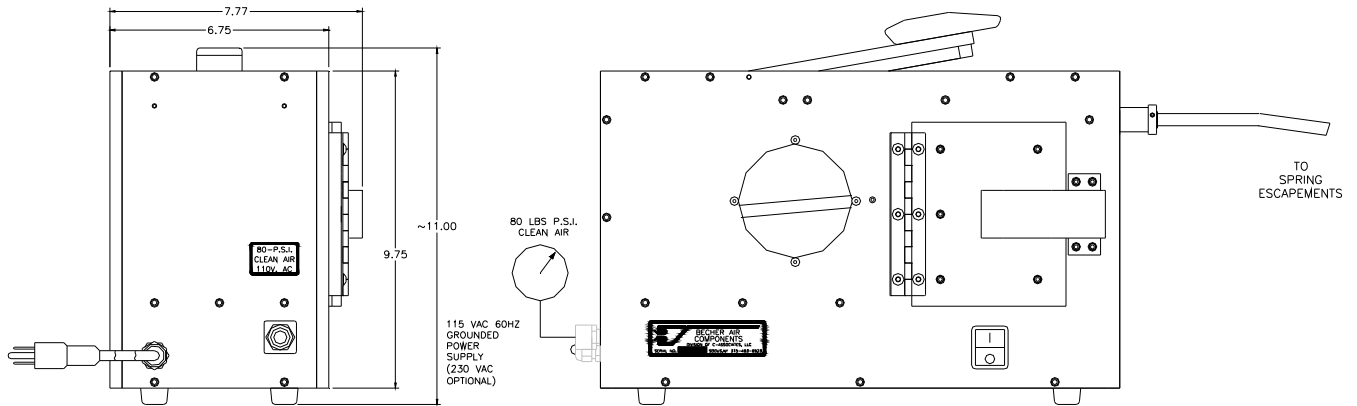
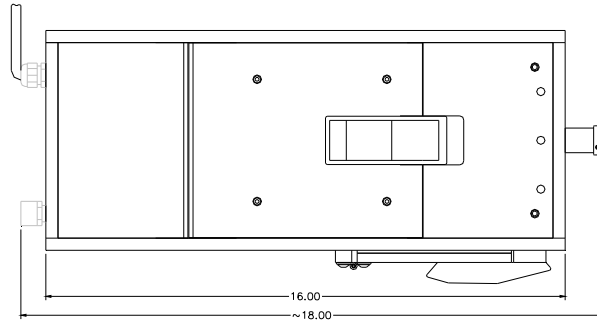

MOUNTING & SPECIFICATIONS

MODEL 602

	US Std. Inches	Metric (mm)
Spring O.D.	.125 - .312	3.2 - 8 mm
Spring Length	1.250	31.8 mm
Capacity (Vol)	1.5 qt.	1.4 ltr.
Electrical	115 VAC, 1.5A	230VAC, 1A
Air	80 p.s.i.	5.6 kg/cc ²
Air Supply	.375 min.	10 mm min.

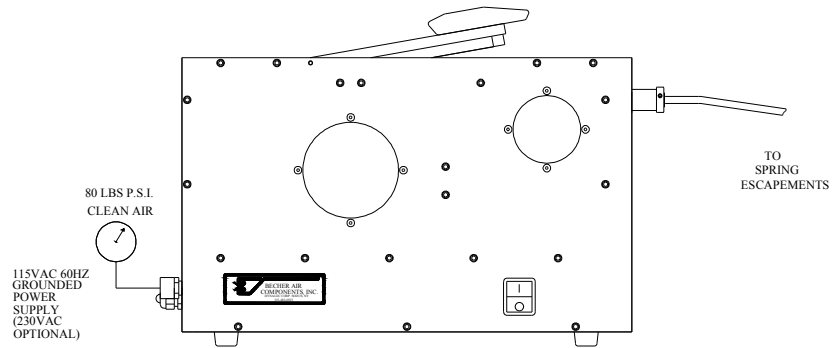
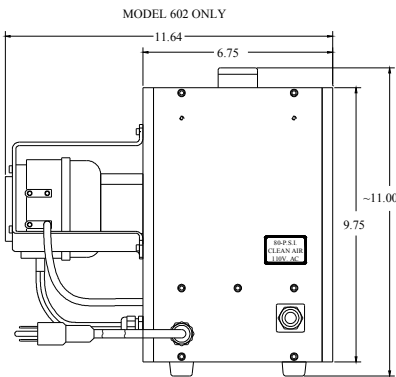
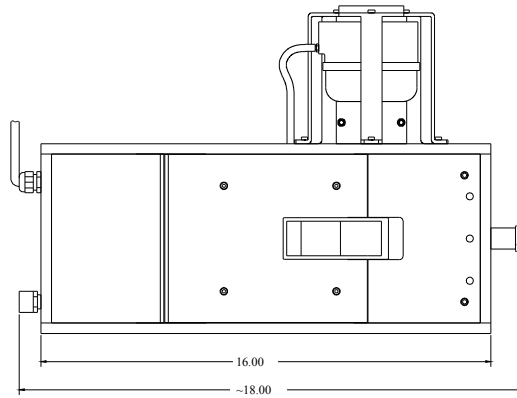

MOUNTING & SPECIFICATIONS

MODEL 652

	US Std. Inches	Metric (mm)
Spring O.D.	.250 - .625	6.35 – 15.88 mm
Spring Length	1.500	38.1 mm
Capacity (Vol)	3 qt.	2.8 ltr.
Electrical	115 VAC, 1.5A	230VAC, 1A
Air	80 p.s.i.	5.6 kg/cc ²
Air Supply	.375 min.	10 mm min.

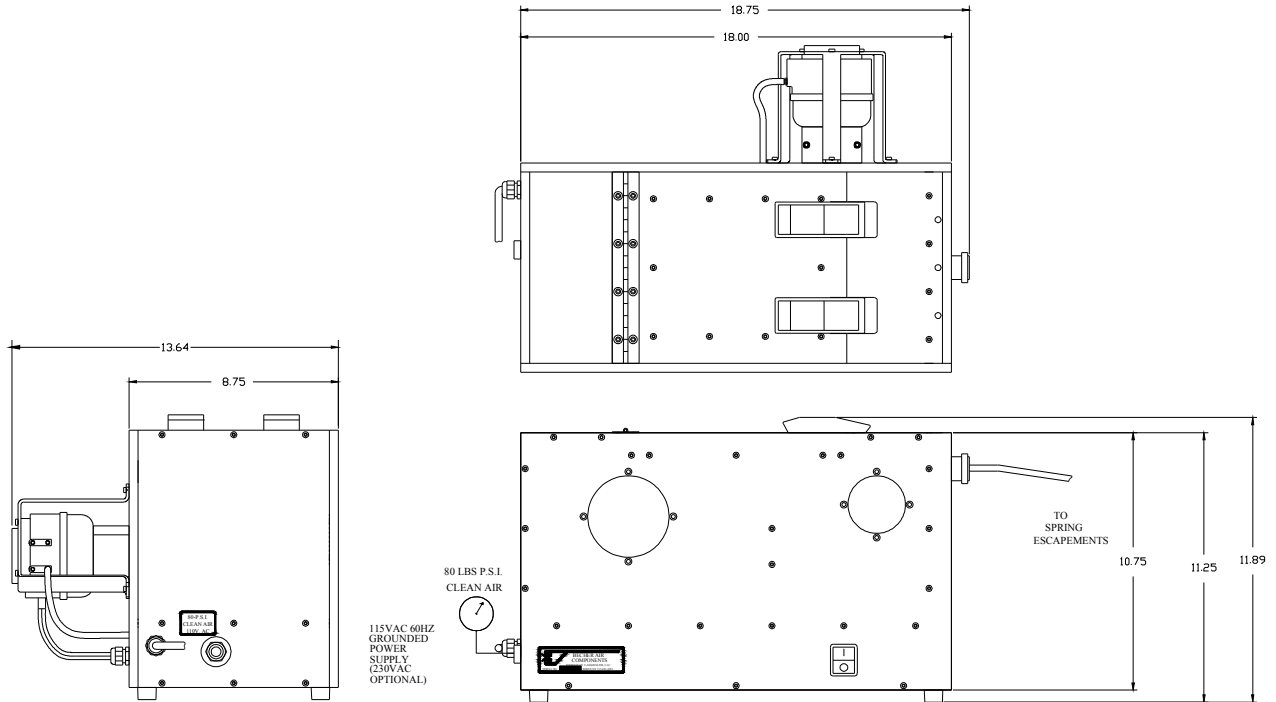

MOUNTING & SPECIFICATIONS

AUTOMATIC ESCAPEMENT

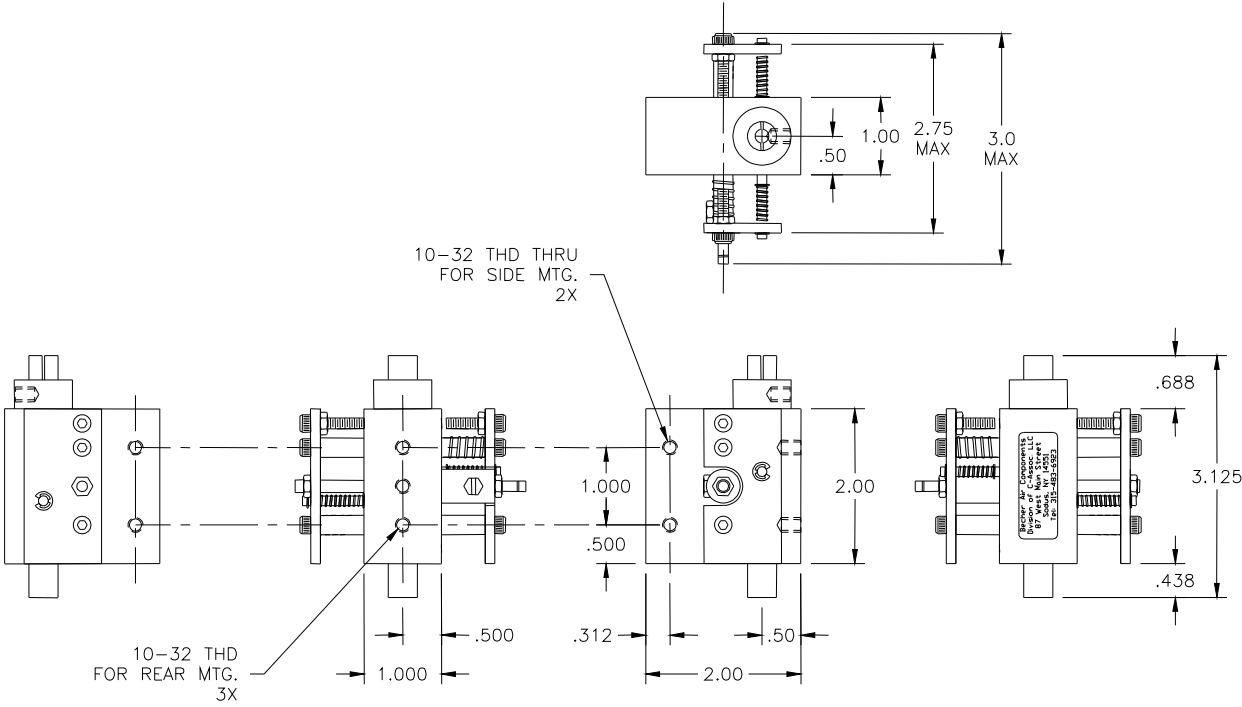

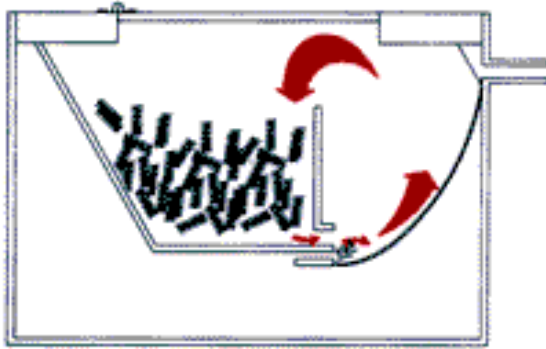

Figure 1

outlet nozzle, (Fig. 2). A cycle timer provides an air jet to clear the nozzle of tangled springs (Fig.3). The springs are then fed down the feed tube to the spring escapement.

The Becmatic Spring Feeder/ Detangler takes a quantity of springs from the rear chamber and feeds them forward to the spinning chamber where they are separated, (See Fig.1.) and fed to the

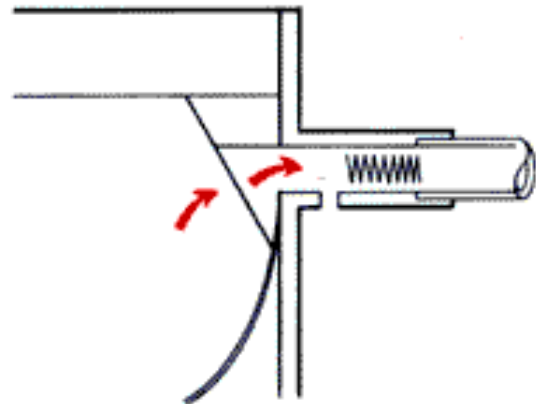

Figure 2

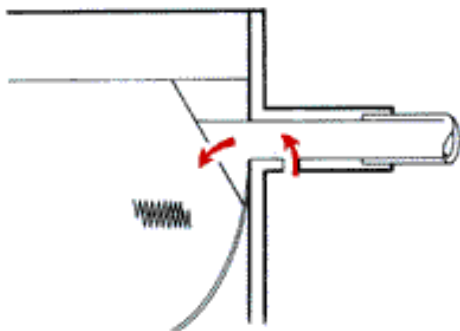

Figure 3

Load springs into the rear chamber of the spring feeder/detangler. It is recommended that the quantity be kept to no more than is necessary to prevent excessive spinning of springs, which may result in hooked or damaged parts.

- * Severely tangled or hooked springs should be removed from the reservoir prior to adding new parts.
- * Springs should be stored in closed containers to avoid contamination and damage.
- * Springs should be clean, dry and free of lubricants or any foreign contamination.
- * Foreign debris and damaged parts may cause jamming or impair feed rates.
- * Power to the machine should be shut off when the feeder is not in use.

OPTIONAL EQUIPMENT

A standard automatic, single station escapement unit can be supplied for mounting at an assembly station. Four tapped #10-32 mounting holes are provided. Units with multiple outlet escapements can be quoted on request.

The **Automatic Escapement** is mounted below the spring feeder and will dispense one (1) spring when activated by an air signal. The factory supplies this unit with a restricting fitting installed on the air cylinder. If this fitting is removed, the air signal provided by the customer must be controlled air. Full line flow/pressure will damage the unit.



An **Automatic Escapement Timer** (PN: 69000-775) may be used to automatically actuate the escapement at a pre-determined time interval. The time interval may be varied allowing the customer to dynamically adjust their spring dispensation rate.

The automatic escapement can also be actuated via an optional **Air Operated Foot-Pedal** (not shown). This unit allows the user of an auto escapement to manually dispense a spring as desired by stepping on the foot-pedal. Depressing the pedal allows air to pass through to the escapement and thus actuate the solenoid.

OPTIONAL EQUIPMENT

A **Pen-type Escapement** is available for manually releasing one spring at a time into position. Units are tooled for specific spring sizes up to .250 inch diameter and .500 inch long.



The **Bench-type Escapement** provides for dispensing of one spring at a time for manual pickup and placement. Available for spring sizes .250 to .500 inch diameter.



TROUBLE SHOOTING

PROBLEM	CAUSE	SOLUTION
Unit will not operate, ON/OFF, Switch does not light.	No Power	Check power source, restore as necessary
	Fuse Blown	Remove Base Panel, replace inline fuse
	Faulty Switch	Replace On/Off Switch
Unit will not operate – ON/OFF Switch is lit	No air to unit	Restore air supply
	Timer not cycling	Replace timer
	Air valve not shifting	Replace air valve
Unit runs – will not feed springs	Nozzle obstructed	Remove and clear nozzle
	Springs oversized or damaged	Replace springs
	Inadequate air supply	Restore supply to 80 p.s.i.
	Air leaking around door(s)	Adjust door latch/replace gasket
	Window(s) leaking	Replace windows
Unit runs – feed rate inadequate	Supply reservoir over filled	Remove springs to restore operating level
	Insufficient volume in supply reservoir	Add springs to restore operating level
Springs will not feed down tube	Feed tube kinked, worn or obstructed	Replace feed tube
	Springs have been magnetized	Remove and degauss springs
	Springs dirty or oily	Remove and clean springs
	Static charge	Small, light springs are subject to static charge buildup. This may become worse in low humidity conditions. An occasional shot of anti-static aerosol can eliminate this problem. Take care to not saturate the springs. Any liquid – water, oil or solvent will impair spring feed rates.

NOTE 1: It is very important that a clean air supply is maintained. Change all air line filters at 3-month intervals or as required to ensure a continuous clean air supply.

NOTE 2: Never oil any parts on the feeder or escapements, adding oil or lubricants can have a negative impact on feed rates and could void warranty.

FEEDER MAINTENANCE:

- * Once/month. Wipe out inside of feeder using non-ammonia based cleaner to remove excess dust/dirt buildup. (Required less often if using passivated springs.)
- * Once/month. Wipe spring slide ramp with Armor All or Pledge to reduce friction and ensure springs slide freely. More frequent applications may be required depending on the cleanliness of the springs be fed.
- * Every 3 months. Check/tighten paddlewheel assembly mounting screws if applicable.
- * Once/year. Check paddlewheel inserts for wear. Insert should protrude from paddlewheel body by at least 0.75 inches. (New insert extends 0.84 inches.) If paddlewheel inserts are excessively worn feeder may have difficulty keeping up with required feed rate. (See parts list.)
- * Once/year. Check door gasket for damage or wear which may cause air leaks at door/feeder interface. Replace if necessary. (See parts list.)
- * Once/year. Check for air leaks around windows. Repair using clear RTV. If a window is cracked it should be replaced to prevent air leakage. Any air leaks could affect the feeder's ability to keep up with the required feed rate. (See parts list.)

TUBING FROM FEEDER TO ESCAPEMENT:

* The tubing, which carries the springs from the feeder to the escapements, will get worn to a point where the springs have difficulty sliding down to the escapements. The replacement rate varies depending on spring configuration and feed rate. Monitor system to determine the required replacement interval.

ESCAPEMENT MAINTENANCE:

* Every 3 months. Check all air fittings and tighten if necessary.

* Every 3 months. Check all hardware and tighten if necessary. (If hardware is tightened on slide rods be careful not to over torque as this could induce twist into assembly causing it to bind when actuated. Tighten screws on each end of the slide rods to a snug condition then actuate the escapement by hand to verify freedom of movement throughout the actuation range. Complete the tightening in a rotational fashion until all screws are tight. After all hardware is tight verify freedom of movement throughout actuation range.)

PARTS LIST

MODEL 550	115 VOLT	230 VOLT
AIR VALVE (2)	69000-406	69000-406-01
TIMER	69000-404-05	69000-404-06
ON/OFF SWITCH	69000-403	69000-403
PUSHER CYLINDER	69000-412	69000-412
CYLINDER CLEVIS	69000-576	69000-576
DOOR LATCH	69000-415	69000-415
DOOR SEAL	69000-442	69000-442
WINDOW (4)	69000-572	69000-572
MODEL 600/602	115 VOLT	230 VOLT
AIR VALVE (SM)	69000-406	69000-406-01
AIR VALVE (LG)	69000-405	69000-405-01
TIMER	69000-404-05	69000-404-06
ON/OFF SWITCH	69000-403	69000-403
PUSHER CYLINDER	69000-410	69000-410
CYLINDER CLEVIS	69000-496	69000-496
DOOR LATCH	69000-415	69000-415
DOOR GASKET	69000-442	69000-442
WINDOW (4)	69000-616	69000-616
MOTOR	69000-439-01	69000-440
MODEL 652	115 VOLT	230 VOLT
AIR VALVE (SM) (2)	69000-406	69000-406-01
AIR VALVE (LG)	69000-405	69000-405-01
TIMER	69000-404-05	69000-404-06
ON/OFF SWITCH	69000-403	69000-403
MOTOR	69000-439-01	69000-440
PUSHER CYLINDER	69000-411	69000-411
CYLINDER CLEVIS	69000-496	69000-496
PADDLE WHEEL (5)	69000-694	69000-694
PADDLE WHEEL INSERT (10)	69000-695	69000-695
DOOR LATCH (2)	69000-415	69000-415
DOOR GASKET	69000-442	69000-442
WINDOW (2)	69000-616	69000-616
WINDOW (2)	69000-616-02	69000-616-02
ESCAPEMENT	N/A	N/A
AIR SOLENOID	69000-012	69000-012
PIN-FLAT	69000-005	69000-005
PIN-POINTED	69000-005-01	69000-005-01
SPRING-PIN SPRING (2) per	69000-010	69000-010
SPRING-RETRACTION	69000-011	69000-011
E-CLIP	14212-008	14212-008

Ordering Information

Before calling for parts or service, please have your machine serial identification number ready.

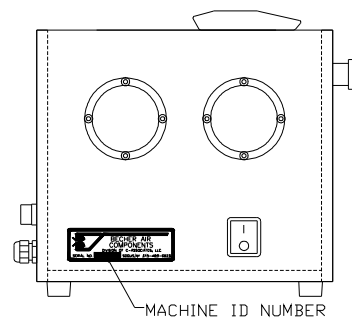

BECHER AIR COMPONENTS
DIVISION OF C-ASSOCIATES, LLC.

SINGLE PORT SPRING FEEDER
TO AUTOMATIC ESCAPEMENT
SET-UP EXAMPLE

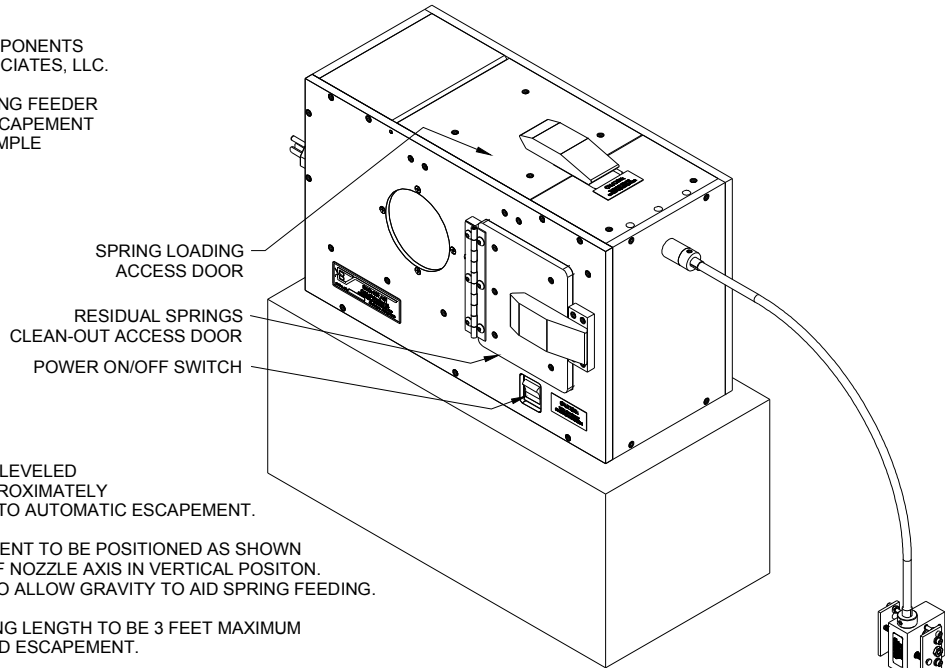

NOTES:

1. THE FEEDER IS TO BE LEVELED AND POSITIONED APPROXIMATELY AS SHOWN RELATIVE TO AUTOMATIC ESCAPEMENT.
2. AUTOMATIC ESCAPEMENT TO BE POSITIONED AS SHOWN WITH ORIENTATION OF NOZZLE AXIS IN VERTICAL POSITON. THIS IS NECESSARY TO ALLOW GRAVITY TO AID SPRING FEEDING.
3. RECOMMENDED TUBING LENGTH TO BE 3 FEET MAXIMUM BETWEEN FEEDER AND ESCAPEMENT.
4. TUBING, BETWEEN FEEDER AND ESCAPEMENT, SHOULD BEND FROM HORIZONTAL TO VERTICAL AS SOON AS POSSIBLE WITHOUT DEFORMING TUBING INSIDE DIAMETER.
5. IF NECESSARY, AUTOMATIC ESCAPEMENT MAY BE MOUNTED ON MECHANISM TO MOVE ESCAPEMENT VERTICALLY BETWEEN SPRING DISPENSING. (RECOMMEND TRAVEL BE LIMITED TO 1-1/2 INCHES MAX.)
6. CUSTOMER TO SUPPLY THE FOLLOWING;
 - A. 80 PSI, CLEAN , FILTERED AIR SUPPLY INPUT TO FEEDER.
 - B. MOUNTING BRACKETS TO POSITION AUTOMATIC ESCAPEMENT.
 - C. UP TO 80 PSI, CLEAN, FILTERED AIR SUPPLY INPUT TO AUTOMATIC ESCAPEMENT.
 - D. METHOD TO CONTROL AIR SUPPLY FOR AUTOMATIC ESCAPEMENT ACTUATION TIMING.

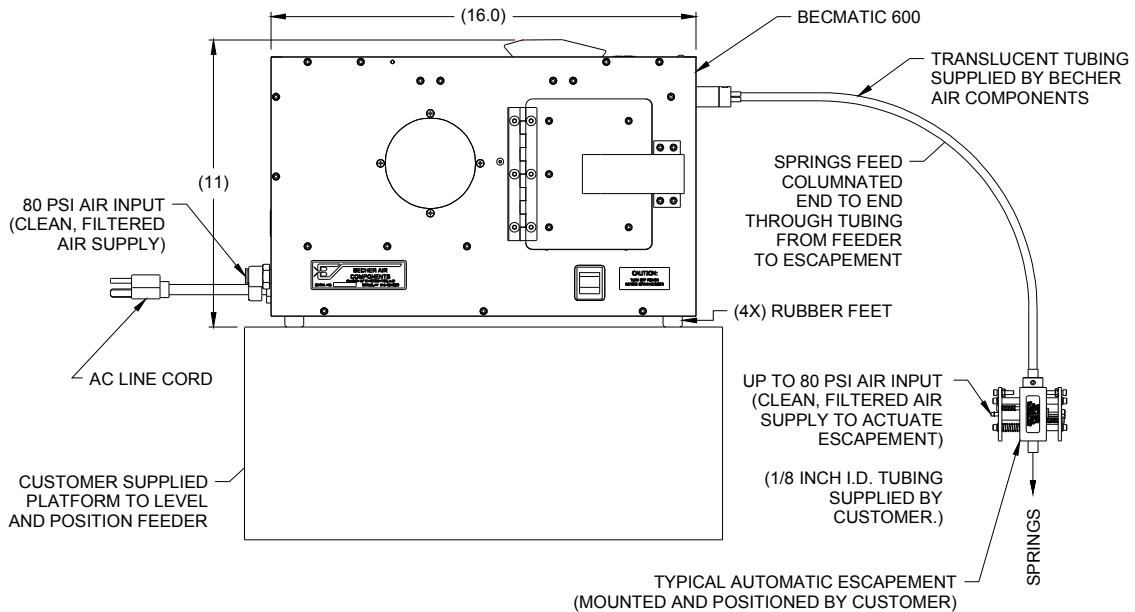

(ESC. ASSY. MAY BE ROTATED ABOUT NOZZLE AXIS TO POSITION ESCAPEMENT BODY AS REQUIRED TO ACCOMODATE CUSTOMER'S MOUNTING BRACKET AND AIR SUPPLY LINE.)